

## Stainless Steel Accessories

### BOLTLESS STAINLESS STEEL OR PAINTED VISOR – ULTRACAB, 2002+

#### INSTALLATION INSTRUCTIONS

1. Remove factory visor, saving end bolts for later use.
2. Drill through rivets on existing brackets first, using a 1/8" drill bit, followed by a 1/4" drill bit. Do not drill deeper than the length of the steel nutserts into cab to avoid drilling through headliner inside of cab.
3. Install steel nutserts into cab using tool provided. Longer nutserts to be used in bottom holes.
4. Ensure that brackets fit effortlessly into the notches in hems on visor panels.
5. The new stainless steel brackets are marked according to where they go, their positions are as follows:

INNER – Inner bracket located at centre of truck. (two of each)

CENTRE – Centre bracket located between outer and inner bracket. (two of each)

OUTER – Outer bracket located to the outside of the truck. (two of each)

SLIDE LOCK – Slide lock brackets attached to each of the main brackets

6. Attach the new main brackets and slide lock brackets onto cab using supplied 1/4" x 20-1" hex head bolts; 1/4" - lock washers and 1/4" - flat washers, according to their respective position Figure 1. Do not fully tighten to allow for adjustment.

- |   |
|---|
| 1 – main bracket (OUT, IN, CEN)           |
| 2 – slide lock bracket (6)                |
| 3 – silicone on face of each bracket      |
| 4 – 1/4-20 x 1" SS hex head bolt (12)     |
| 5 – 1/4 – SS lock washers (12)            |
| 6 – 1/4 – SS flat washers (24)            |
| 7 – 1/4-20 – SS locknut (12)              |
| 8 – 1/4-20 x 3/4" – SS carriage bolt (12) |
| 9 – 1/4-20 x 0.612" – nutsert (6) (top)   |
| 10 – 1/4-20 x 0.706" nutsert (6) (bottom) |

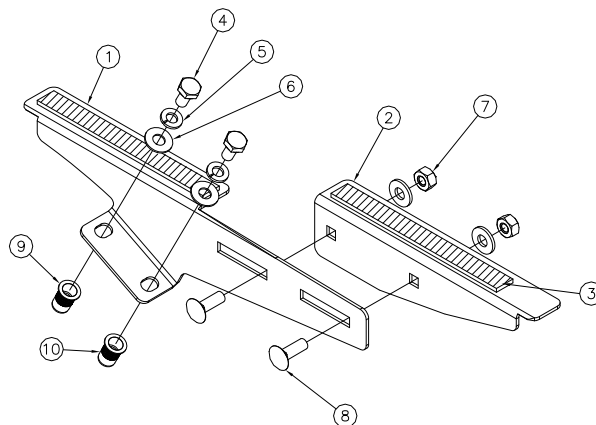

7. Apply supplied silicone generously to brackets along the face where the visor will be resting as shown in Figure 1.
8. Apply a generous amount of silicone caulking in and around all nutserts in cab.

9. Remove plastic film from hem and flange of visor panel.
10. Slide visor panel onto brackets at top ensuring that the brackets are in the notches of the hem.
11. Install bolts joining the visor halves together leaving loose.
12. Loosely install end bolts.
13. Tighten bolts that join visor together.
14. Ensuring that the brackets are as far in the notches as possible along top of visor, push locking bracket as far as possible into bottom hem and tighten the locking bracket.
15. Tighten cab brackets.
16. Remembering to peel the plastic from under the bolt heads, tighten end bolts.
17. Remove the remaining protective film.